

Ion Channels

John Koester
jdk3

References:

- Kandel, Schwartz and Jessell (2000):
Principles of Neural Science, 4th edition, chapter 5
- Hille, B. (2001) *Ion Channels of Excitable Membranes*, 3rd edition

Outline

- Why ion channels?
- Channel structure
- Ion channels have three basic functional properties
 - ◆ Conduct
 - ◆ Select
 - ◆ Gate
- Evolutionary relationships between ion channels
- Various factors contribute to ion channel diversity

Ions Cannot Diffuse Across the Hydrophobic Barrier of the Lipid Bilayer

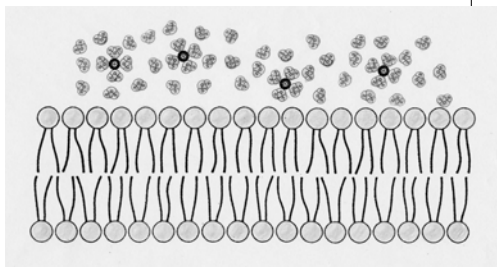

Ion Channels Provide a Polar Environment for Diffusion of Ions Across the Membrane

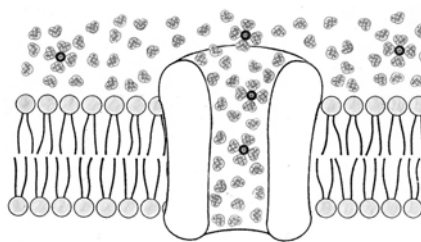

Specialized Functions of Ion Channels

- Mediate the generation, conduction and transmission of electrical signals in the nervous system
- Control the release of neurotransmitters and hormones
- Initiate muscle contraction
- Transfer small molecules between cells (gap junctions)
- Mediate fluid transport in secretory cells
- Control motility of growing and migrating cells
- Provide selective permeability properties important for various intracellular organelles

Outline

- Why ion channels?
- Channel structure
- Ion channels have three basic functional properties
 - ◆ Conduct
 - ◆ Select
 - ◆ Gate
- Evolutionary relationships between ion channels
- Various factors contribute to ion channel diversity

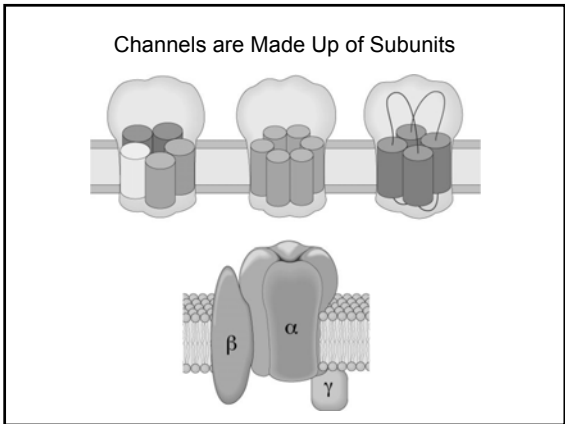

- Outline**
- Why ion channels?
 - Channel structure
 - Ion channels have three basic functional properties
 - ◆ Conduct
 - ◆ Select
 - ◆ Gate
 - Evolutionary relationships between ion channels
 - Various factors contribute to ion channel diversity

- Conduction**
- Ion Channels Conduct Up to 10^8 Ions/sec
 - Ion Channels Act As Catalysts
 - Speed up fluxes
 - Do not impart energy
 - Driving force is provided by electrochemical potential

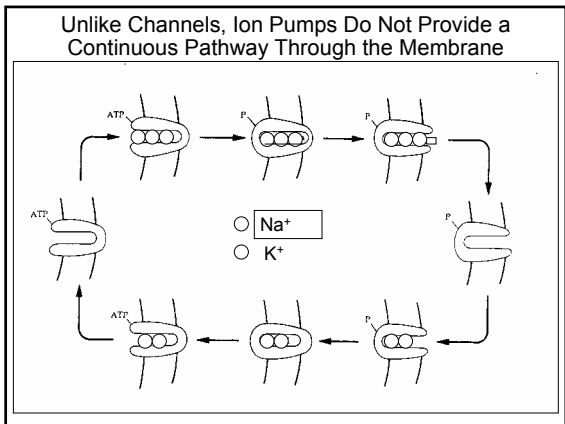

- Outline**
- Why ion channels?
 - Channel structure
 - Ion channels have three basic functional properties
 - ◆ Conduct
 - ◆ Select
 - ◆ Gate
 - Evolutionary relationships between ion channels
 - Various factors contribute to ion channel diversity

Ion Channels are Selectively Permeable

Cation Permeable	Anion Permeable
Na ⁺	Cl ⁻
K ⁺	
Ca ⁺⁺	
Na ⁺ , Ca ⁺⁺ , K ⁺	

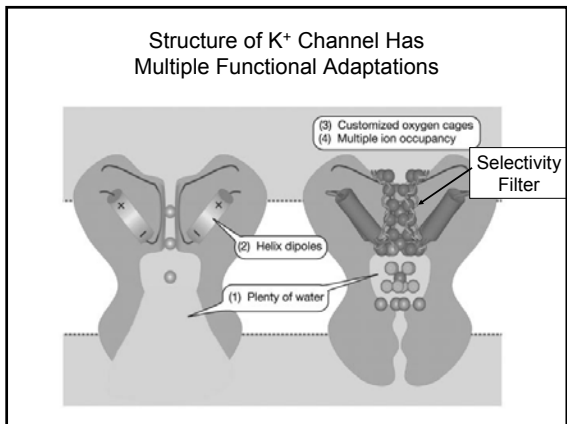

- ### Outline
- Why ion channels?
 - Channel structure
 - Ion channels have three basic functional properties
 - ◆ Conduct
 - ◆ Select
 - ◆ Gate
 - Evolutionary relationships between ion channels
 - Various factors contribute to ion channel diversity

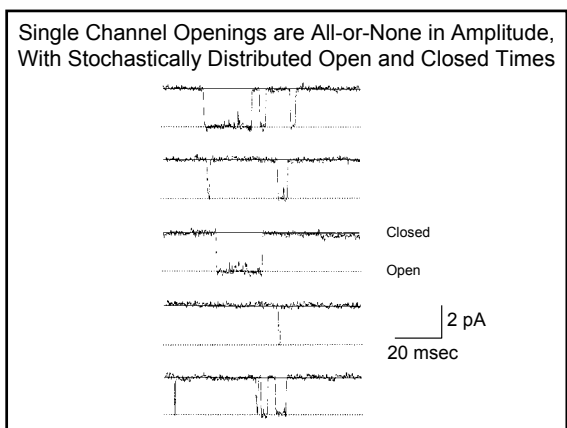

There are Two Major Types of Gating Actions

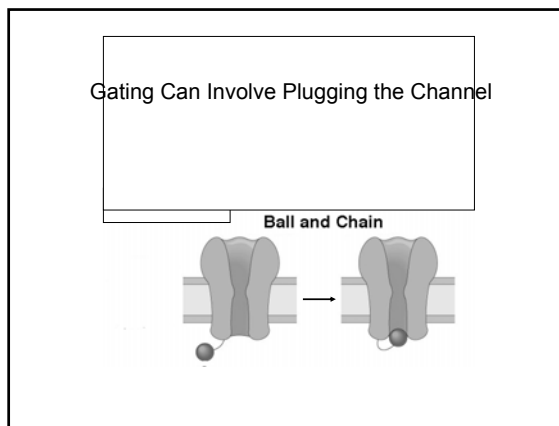
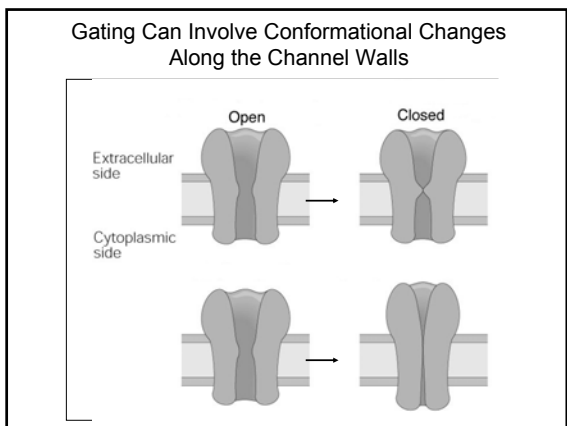

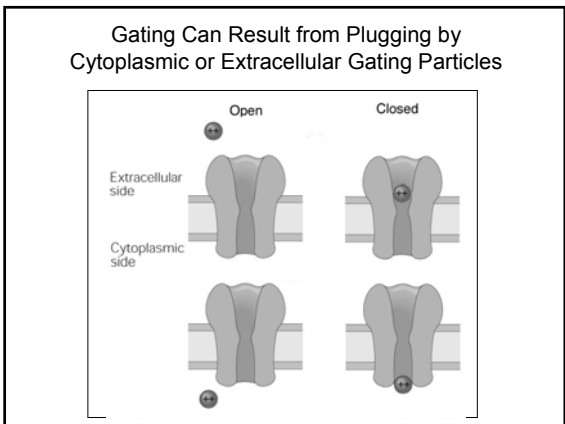

There are Five Types of Gating Controls

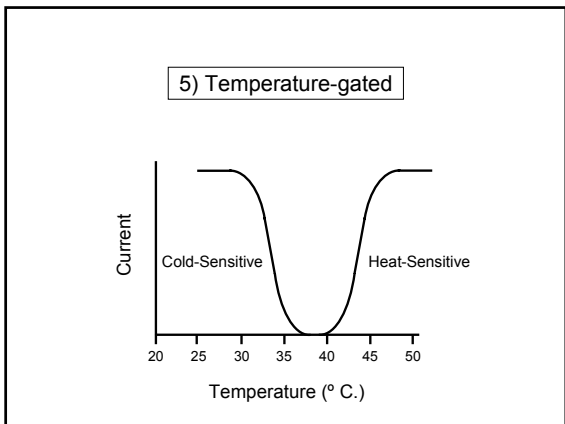
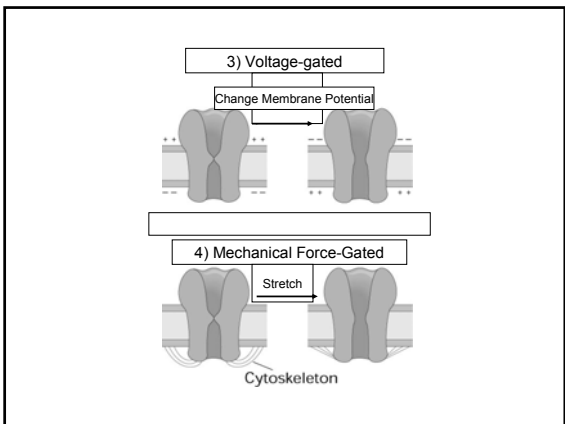
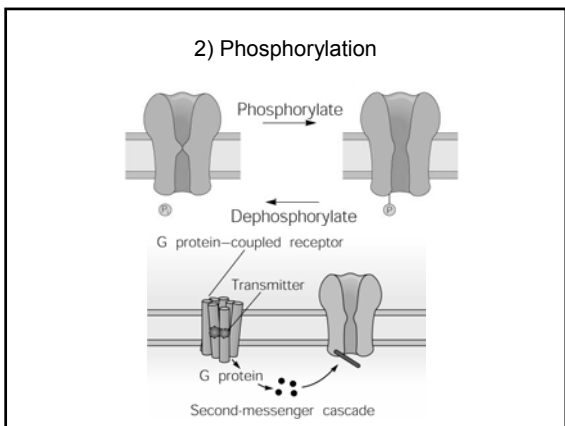
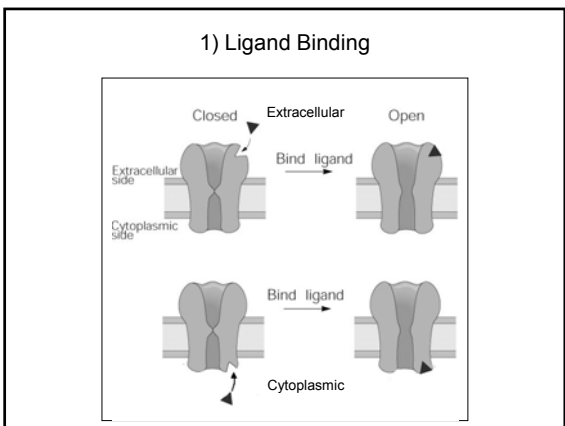

Modifiers of Channel Gating

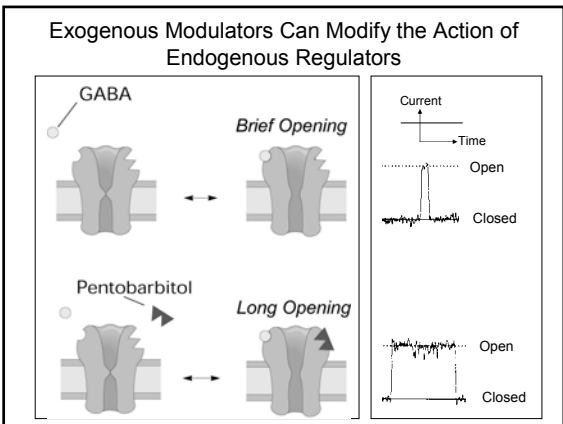
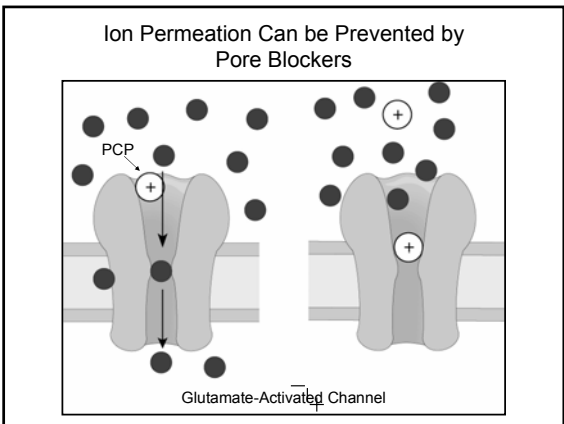
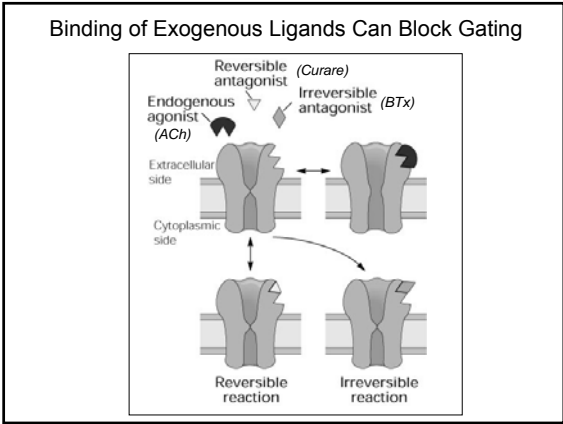

- ### Outline
- Why ion channels?
 - Ion channels have three basic functional properties
 - ◆ Conduct
 - ◆ Select
 - ◆ Gate
 - Evolutionary relationships between ion channels
 - Various factors contribute to ion channel diversity

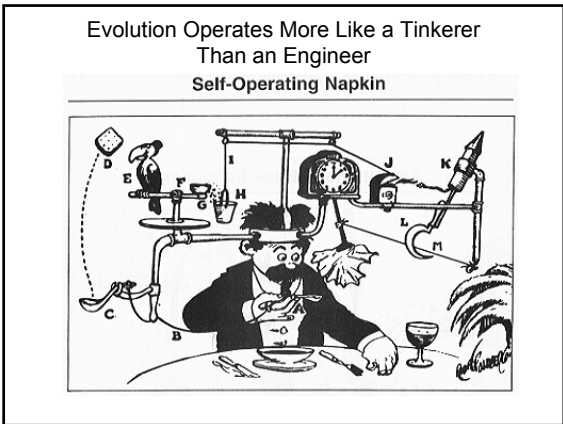

Ion Channel Gene Superfamilies

I) Channels Activated by Neurotransmitter-Binding (pentameric channel structure):

- Acetylcholine
- GABA
- Glycine
- Serotonin

II) Channels Activated by ATP or Purine Nucleotide-Binding (quatrameric or trimeric channel structure)

Ion Channel Gene Superfamilies

III) Channels With Quatrameric Structure Related to Voltage-Gated, Cation-Permeant Channels:

A) Voltage-gated:

- K⁺ permeant
- Na⁺ permeant
- Ca⁺⁺ permeant
- Cation non-specific-permeant

B) Cyclic Nucleotide-Gated (Cation non-specific-permeant)

C) TRP Family (Cation Non-specific); Gated by:

- osmolarity
- pH
- mechanical force (hearing, etc.)
- ligand binding
- temperature

D) Channels Activated by Glutamate-Binding

- quatrameric channel structure
- cation non-specific permeability

Ion Channel Gene Superfamilies

IV) "CLC" Family of Cl⁻-Permeant Channels (dimeric structure):

Gated by:

- Voltage
- Cell Swelling
- pH

V) Gap Junction Channels (non-specific permeability; hexameric structure)

Outline

- Why ion channels?
- Channel structure
- Ion channels have three basic functional properties
 - ◆ Conduct
 - ◆ Select
 - ◆ Gate
- Evolutionary relationships between ion channels
- Various factors contribute to ion channel diversity

